

# sensory furniture

**sensign**<sup>®</sup>  
SENSORY PRODUCTS

# OUR PRODUCTS

## **sensory table**

	<b>page</b>
- <b>ST</b> sensory table round	<b>1</b>
- <b>STL</b> sensory table linear	<b>6</b>
- product information	<b>11</b>
- technical information	<b>14</b>
- <b>CLT</b> table system	<b>15</b>
- technical information	<b>17</b>

## **sensory cabin system**

- <b>SCS basic</b> sensory cabin	<b>18</b>
- <b>SCS pro+</b> sensory cabin	<b>20</b>
- technical information	<b>23</b>
- <b>SCS light</b> sensory cabin	<b>27</b>
- <b>SCS partition</b> panel	<b>29</b>

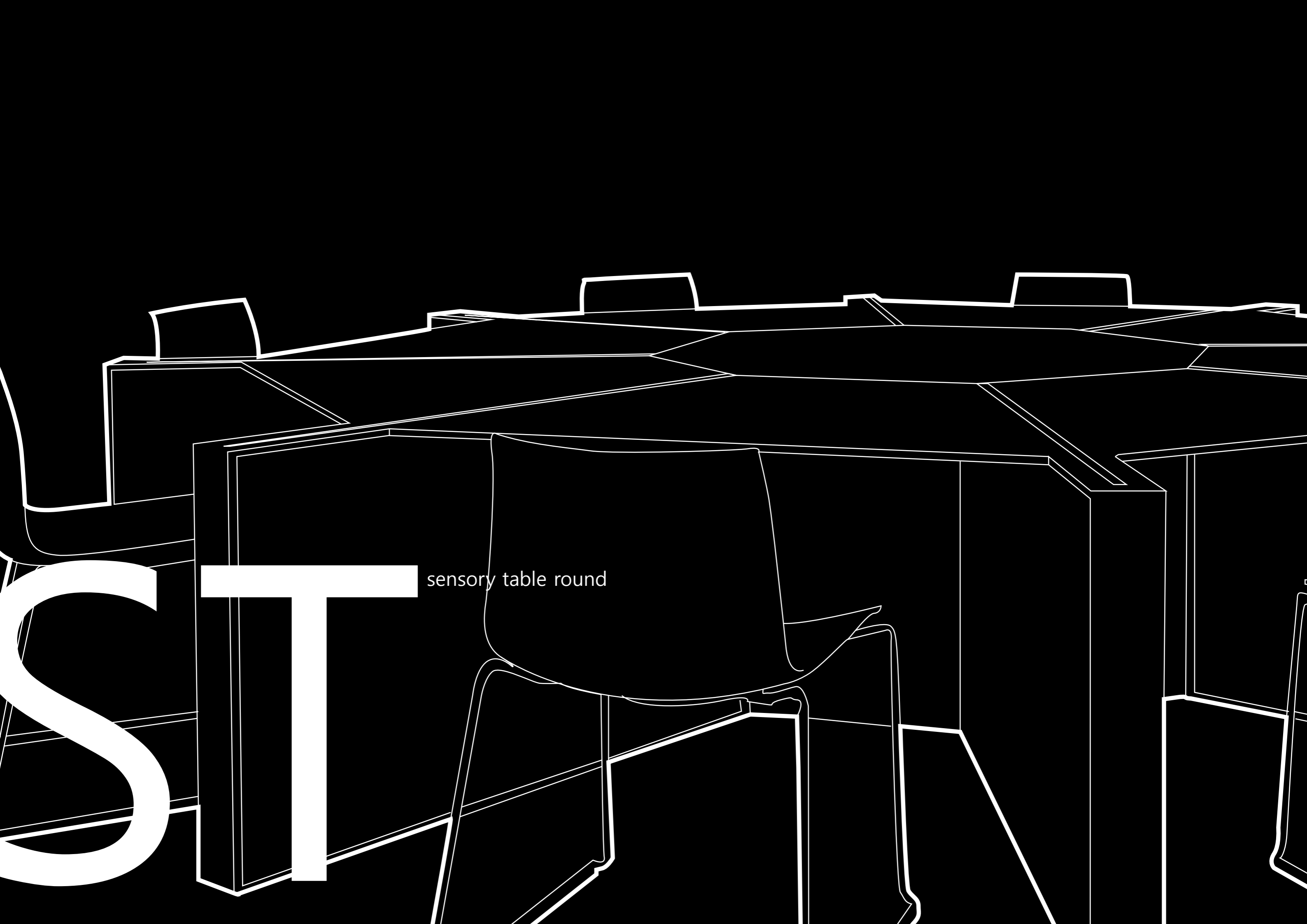

S

T

sensory table round



## Sensory Booths

### ... at the press of a button

Transforming a conventional conference room table into a valuable piece of professional sensory equipment with its smoothly and quickly elevating partitioning walls.

The SAM Sensory Table is the ideal solution even in the smallest of rooms – starting with a size of 8 Sensory Booths as the smallest version with an unlimited potential for growth.

The SAM Sensory Table Booth satisfies all the prerequisites as stated in the sensory DIN-Norm "Group Testing Tables" (see: requirements of test rooms - DIN 10962).





## High Performance Intelligent, Digitized & Modular

- Outstanding material – robust, unbreakable and timeless
- Easy to assemble and disassemble, even while setting up the most complex structure of the table. Completed within minutes and as often as you would like with just two simple tools.
- Intelligent accessories: integrated LED lighting adjustable to the entire color-spectrum, moderator work-space, all types of connections, networking capabilities, data interfaces and much more reflect state of the art technology realized.
- Simple operation by a smartphone, tablet or laptop app.
- Unlimited sensory table configuration, adaptable to each room size and shape, allowing adjustability to any requirement for the life your investment.
- Add or remove Sensory Booth as required.



## Configuration: Round – Oval

Individual working places are configured either trapezoid or rectangular shaped allowing an adjustment to any type of room.

Design-Examples ST with trapezoid working places:

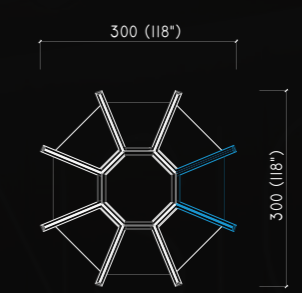

ST 08 For 8 Persons or 7 Persons + Moderator

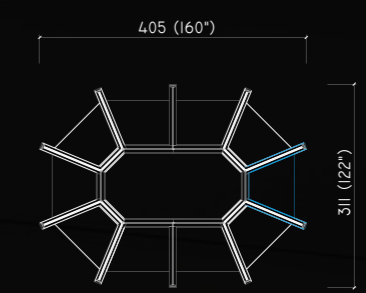

ST 10 For 10 Persons or 9 Persons + Moderator

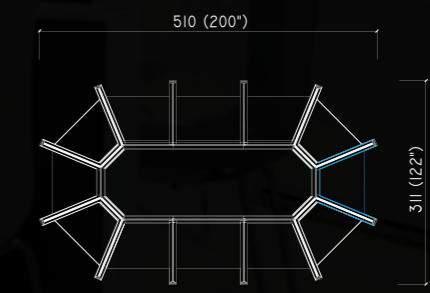

ST 12 For 12 Persons or 11 Persons + Moderator

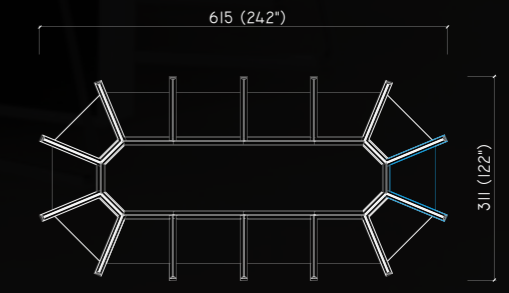

ST 14 For 14 Persons or 13 Persons + Moderator



Assembly Screws



Power Socket, Network, USB



Swivel for Height-Adjustment



Synchronisation of Partitioning Walls



Cable Routing with Dust/Dirt Protection

## Unlimited Modular

- Quick, easy and do-it-yourself assembly / disassembly: two simple tools are all you need.
- Regardless of the individual shape of the working space, a sensory table can be easily modified by adding, removing or reconfiguring with working place / Sensory Booth modules.
- A single module makes up one fully wired working place, including power socket, data interface, USB charging port, LAN-connection.
- Portability: moving from one room to another with ease.

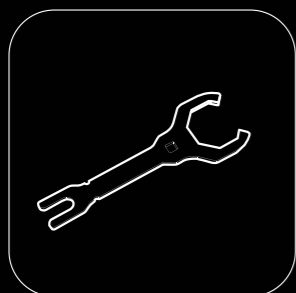

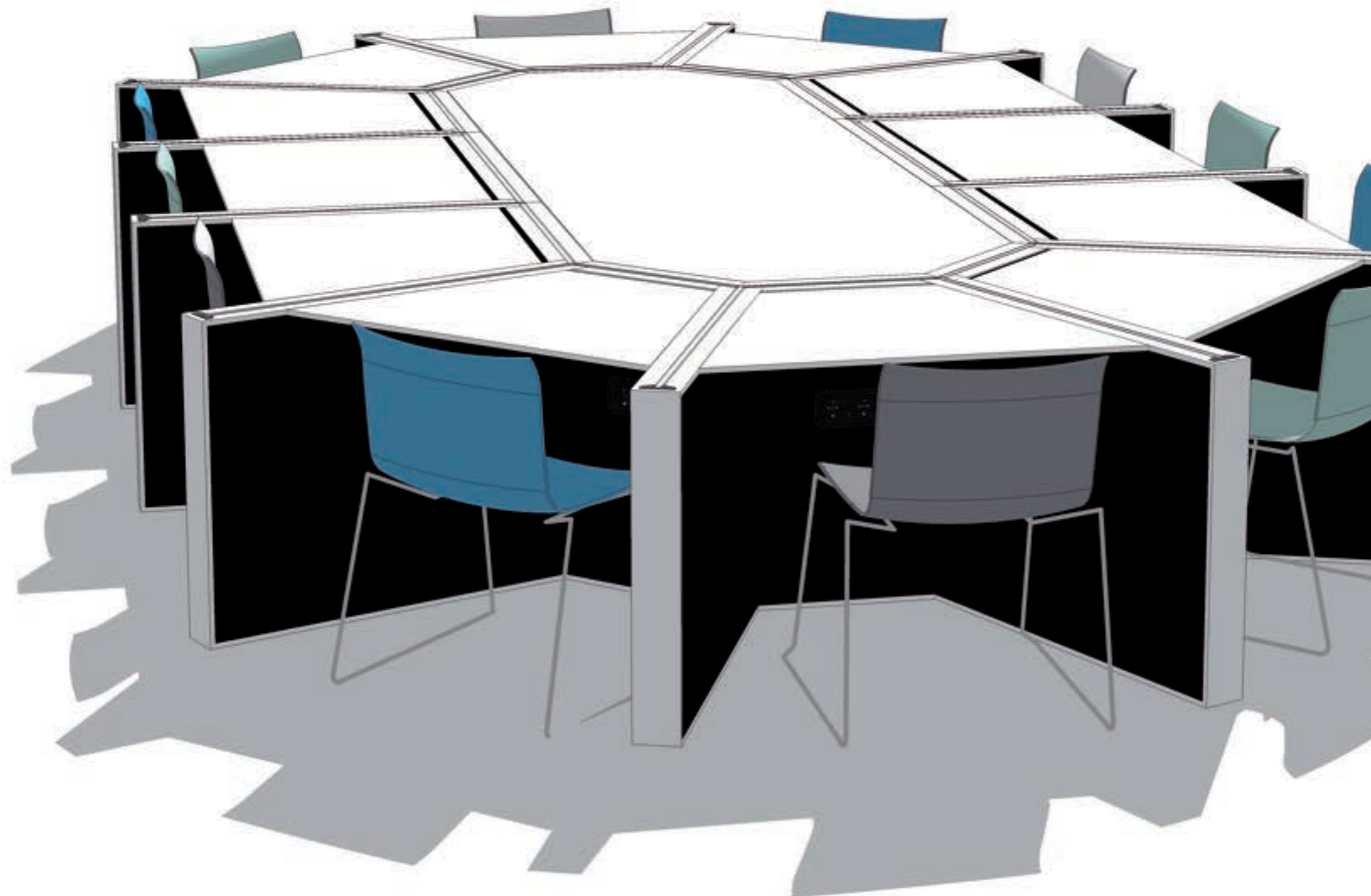

## Points of Difference What sets it apart

- Unlimited modular: Quick, easy and do-it-yourself assembly / disassembly: two simple tools are all you need
- Unlimited sensory table configurations: round, oval, square, linear as well as tailor-made layouts to fit in every room
- Variability of connections: fully wired work space including power socket, data interface, USB charging port, LAN-connection.
- Expandability: add additional working places whenever wanted, even years after investment
- Portability: disassemble transport and re-assemble with ease
- Enlightening Sensory Booth: daylight and entire color spectrum
- Robust, unbreakable, highly resistant and timeless solid surface material of the highest quality
- State of the art operation via app – convenient, centralized, user friendly

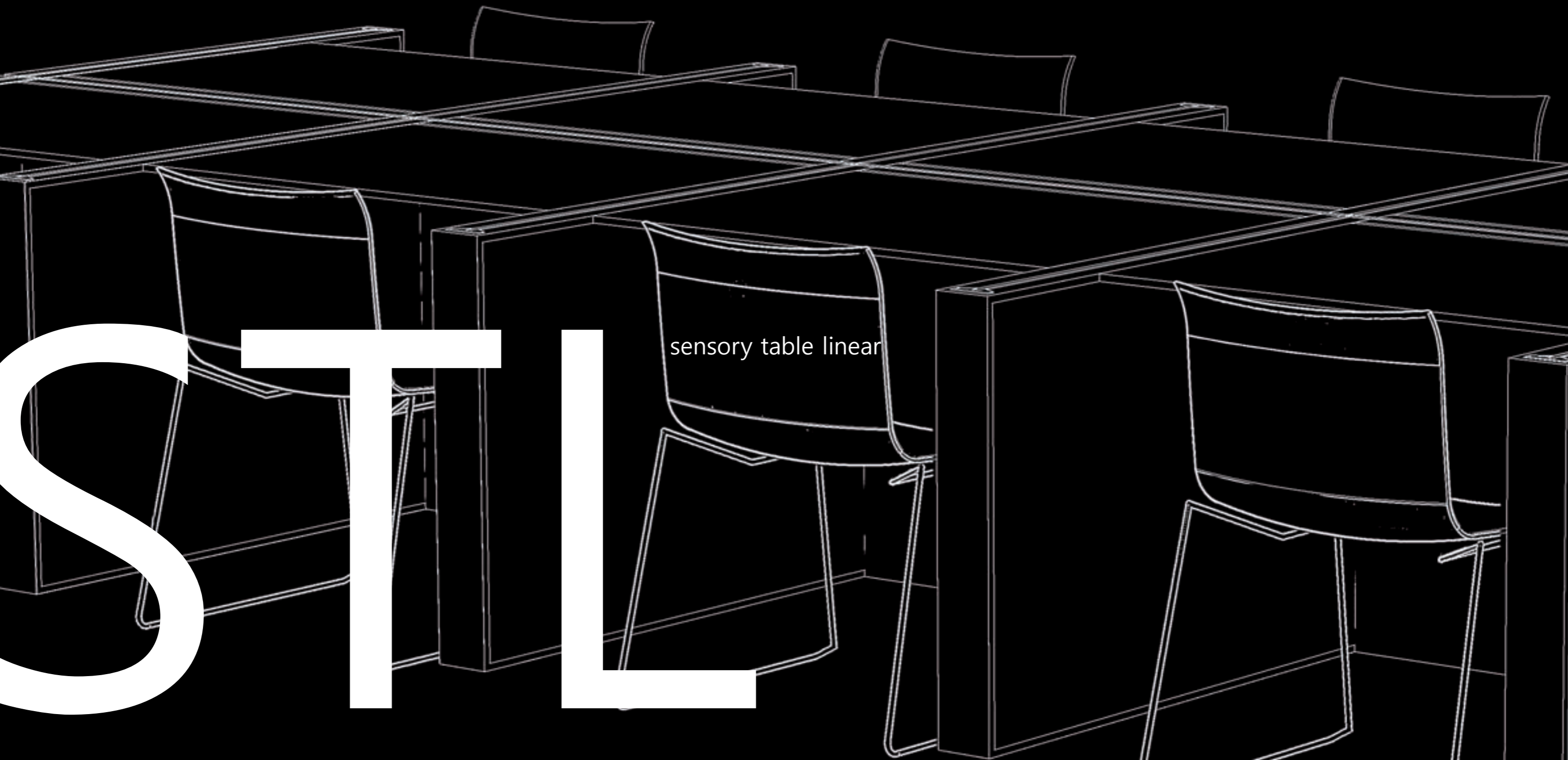

# STILL

sensory table linear





## Sensory Booths

### ... at the press of a button

Transforming a conventional conference room table into a valuable piece of professional sensory equipment with its smoothly and quickly elevating partitioning walls.

The SAM Sensory Table is the ideal solution even in the smallest of rooms – starting with a size of 6 Sensory Booths as the smallest version with an unlimited potential for growth.

The SAM Sensory Table Booth satisfies all the prerequisites as stated in the sensory DIN-Norm "Group Testing Tables" (see: requirements of test rooms - DIN 10962).

### High Performance Intelligent, Digitized & Modular

Outstanding material – robust, unbreakable and timeless. Easy to assemble and disassemble, even while setting up the most complex structure of the table. Completed within minutes and as often as you would like with just two simple tools.

Intelligent accessories: integrated LED lighting adjustable to the entire color-spectrum, moderator work-space, all types of connections, networking capabilities, data interfaces and much more reflect state of the art technology realized.

Simple operation by a smartphone, tablet or laptop app.

Unlimited sensory table configuration, adaptable to each room size and shape, allowing adjustability to any requirement for the life of your investment.

Add or remove Sensory Booth as required.





## Configuration: Square – Linear

The rectangular shape of the working place creates endless design opportunities: L or U forms, open or closed constructions, adjustable to your requirements.

Adjustable width of the working plate enables the adaptation of the number of working places to different room sizes.

Design-Example STL with rectangular working places:

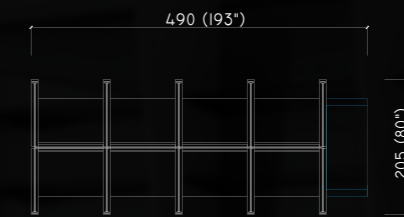

**STL 08 For 8 Persons + Moderator**



**STL 10 For 10 Persons + Moderator**



**STL 12 For 12 Persons + Moderator**

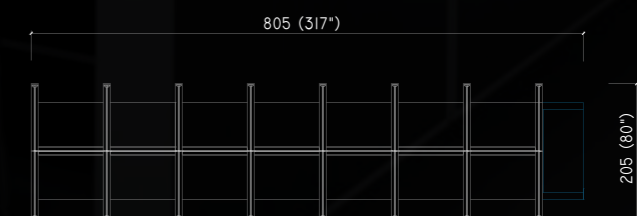

**STL 14 For 14 Persons + Moderator**



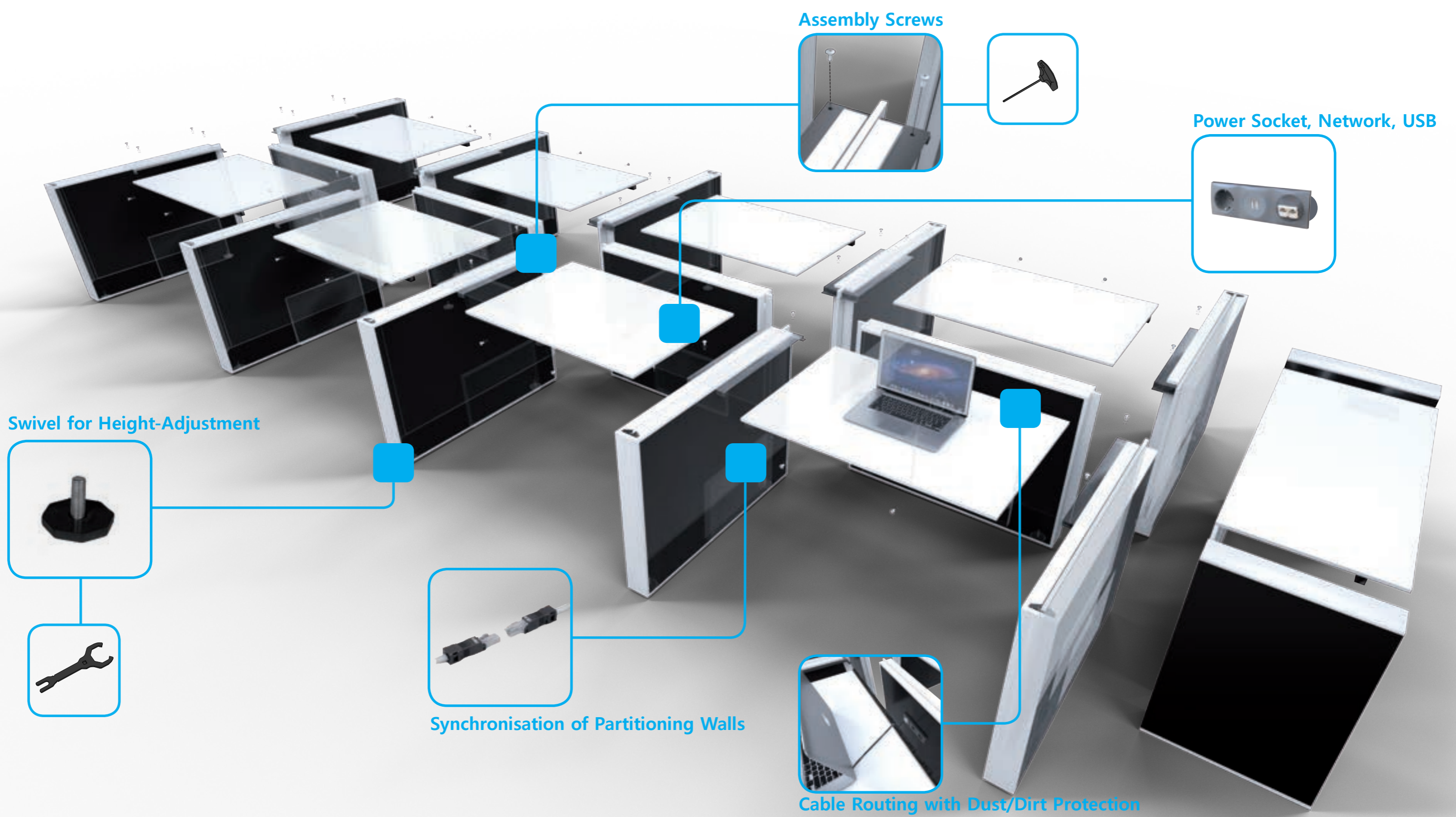

## Unlimited Modular

- Quick, easy and do-it-yourself assembly / disassembly: two simple tools are all you need.
- Regardless of the individual shape of the working space, a sensory table can be easily modified by adding, removing or reconfiguring with working place / Sensory Booth modules.
- A single module makes up one fully wired working place, including power socket, data interface, USB charging port, LAN-connection.
- Portability: moving from one room to another with ease.

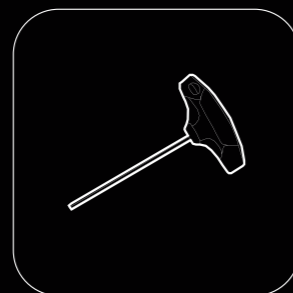
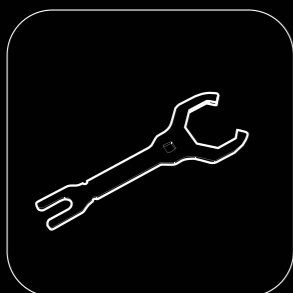





## Points of Difference What sets it apart

- Unlimited modular: Quick, easy and do-it-yourself assembly / disassembly: two simple tools are all you need
- Unlimited sensory table configurations: round, oval, square, linear as well as tailor-made layouts to fit in every room
- Variability of connections: fully wired work space including power socket, data interface, USB charging port, LAN-connection.
- Expandability: add additional working places whenever wanted, even years after investment
- Portability: disassemble transport and re-assemble with ease
- Enlightening Sensory Booth: daylight and entire color spectrum
- Robust, unbreakable, highly resistant and timeless solid surface material of the highest quality
- State of the art operation via app – convenient, centralized, user friendly

## Three usages at the press of a button ... ... elevating partition walls

- **Sensory Booth**  
Partition walls form a complete sensory booth with full separation and protection of each sitting respondent of a descriptive panel. Professional integrated high power LED lighting homogeneously illuminates each work station, allowing daylight as well as the entire color spectrum.
- **Training Tool**  
The perfect combination of the sensory table used for panel training, optimizing the use of rooms increasing the overall working efficiency of each descriptive panel.
- **Conference Table**  
Sophisticated in design and material, elegant and technically state of the art complete with intelligent media technology.

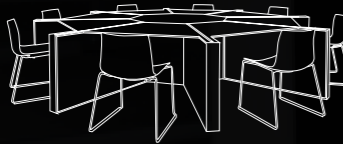
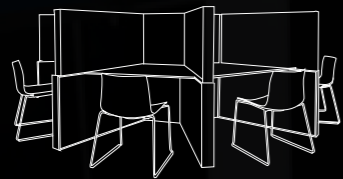



## Enlightening Sensory Booth

- Professional and fully integrated high power LED lighting – crucial for professional product evaluation
- Each working place is homogeneously illuminated, allowing daylight and the entire color spectrum
- Lighting of the working places via remote controlled adjustable
- Room lighting can be included in the light control system

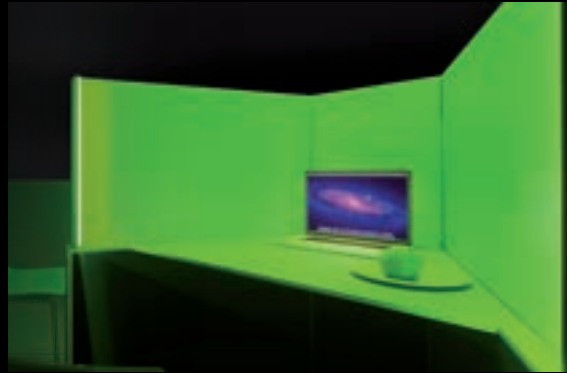

# Material – Practical, Unbreakable and Timeless

Solid surface material is a composite material composed of an acrylic mass, hardened natural minerals (about 75%) and pigments.

With its functional properties, solid surface material can meet the maximum requirements placed on a first-class material in Lab furnitures, preparation kitchens and bathrooms as well as in all conference and training rooms. Therefore it also can be used in high-traffic areas.

Color: Pure White

SWISSCDF (Compact Density Fibreboard) is a black stained HDF board with a high density (>1000 kg/m<sup>3</sup>). Thanks to its construction and finishing with a multi-layer coating of melamine films, SWISSCDF sets new dimensions in design and construction in the area of residential and public interiors. This natural, wood-based board stands out for its stability, scratch resistance, splash water resistance and low flammability.

## Solid Surface

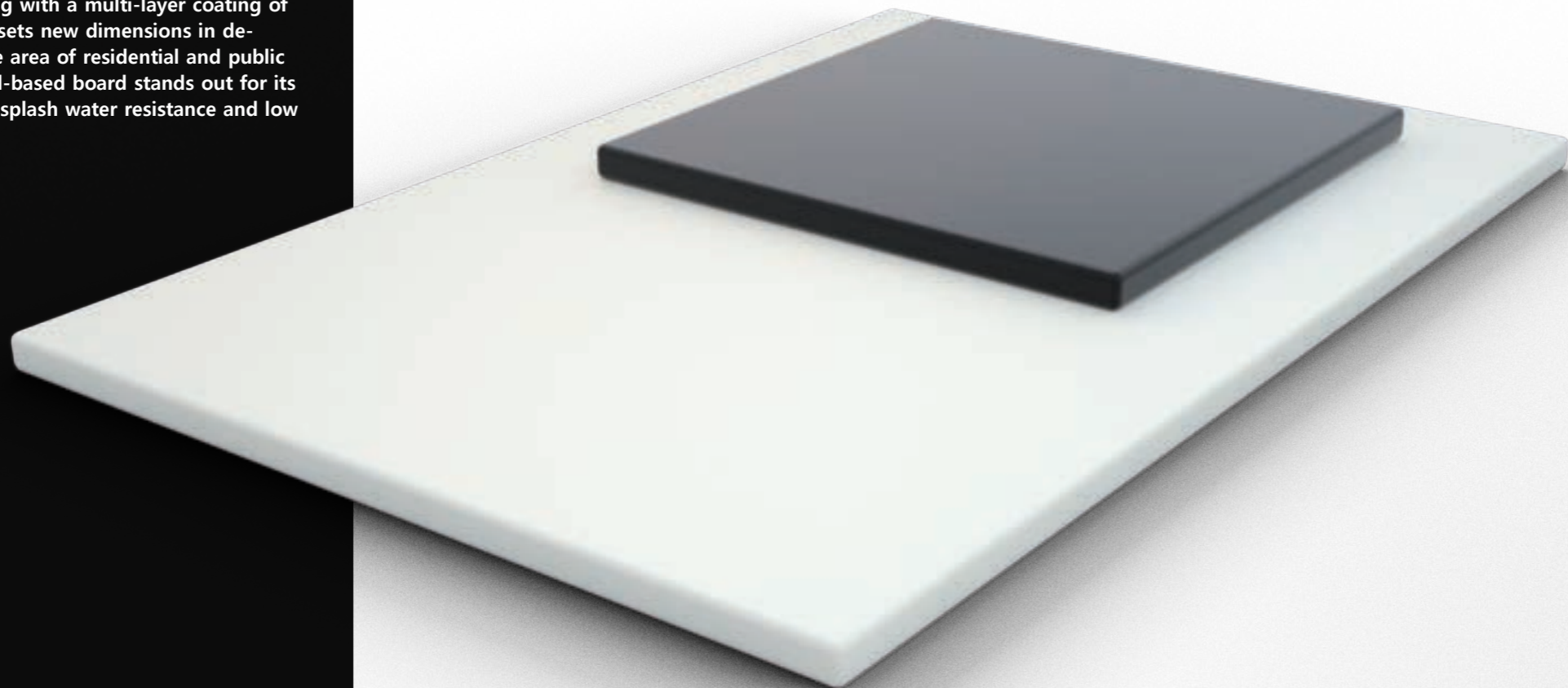

Antistatic



Hydro Repellent



Hygienic



Resistance to Impact



Mold Resistant



Environmentally Friendly

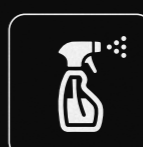

Easy to Clean



Suitable for Contact with Food

\* Colors may differ slightly



# Technical Data

## Functionality:

High-Performance Sensory Table system developed for classical conference and executive usage, training purposes and of course its core function as a Sensory Booth for Descriptive Analysis with elevating partitioning walls transforming the table within less than 5 seconds.

## Partitioning Wall Housing:

Housing with a width of 10 cm (4"). Decor identical to table plate. Cladding with black compact board. 24 cm (9") extended framing. Connection of the housing to table plate with stainless steel 1.4571. Gliders for moving the table with swivel for height-adjustment made of polyurethane and steel.

Elevating partitioning walls made of the same material as the table plate.

## Table Plate / Working Space:

Solid Surface, 12 mm (0,5") strength. Choice of colors. Integrated brush-sealing protecting cable routing from dirt and dust.

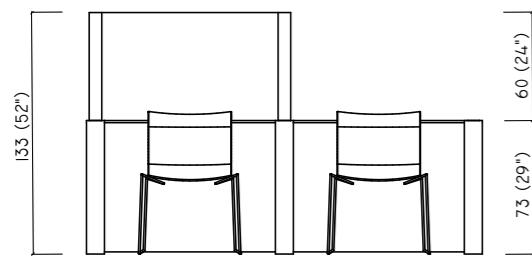

## Moderators Working Area

An individual and specifically designed working place for panel moderations can be added to each configuration of the table

## Accessories:

Panel flap with integrated sockets: power socket, LAN-connection, 1 USB port. Conduit for easy cable routing.

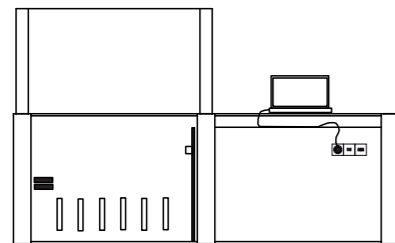

## Operation:

- via remote controlled
- optional control panel via app for laptop, tablet or smartphone operating all functions and connecting with room lighting, blinds, air-condition, door-communication, etc.

# Configuration: Round – Oval – Squared – Linear

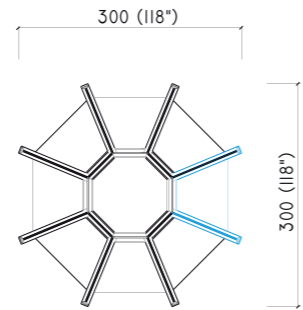

ST 08 For 8 Persons or 7 Persons + Moderator

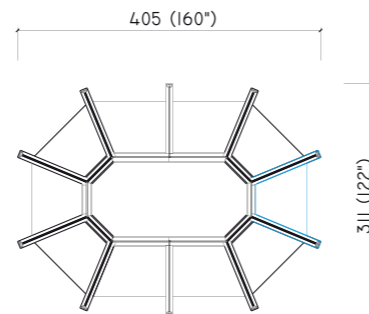

ST 10 For 10 Persons or 9 Persons + Moderator

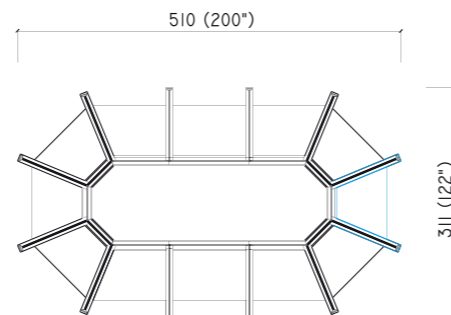

ST 12 For 12 Persons or 11 Persons + Moderator

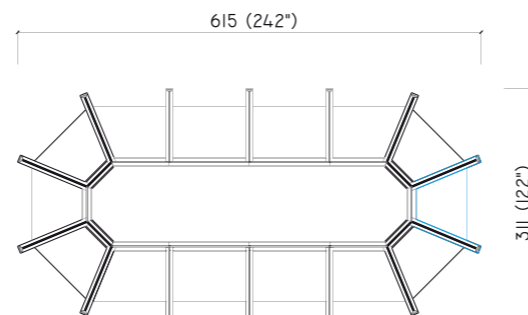

ST 14 For 14 Persons or 13 Persons + Moderator

Other configurations or and table sizes possible.

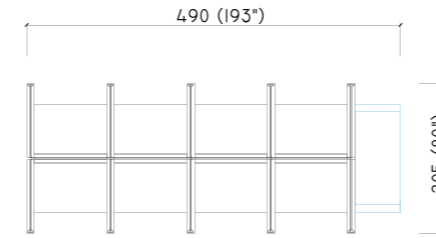

STL 08 For 8 Persons + Moderator

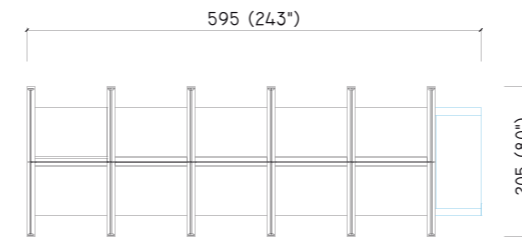

STL 10 For 10 Persons + Moderator

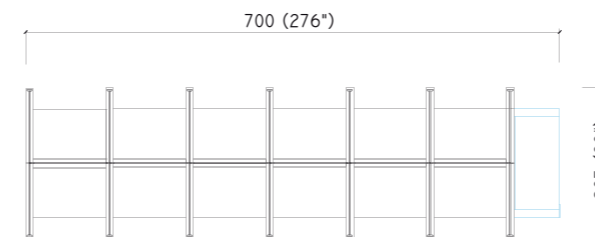

STL 12 For 12 Persons + Moderator

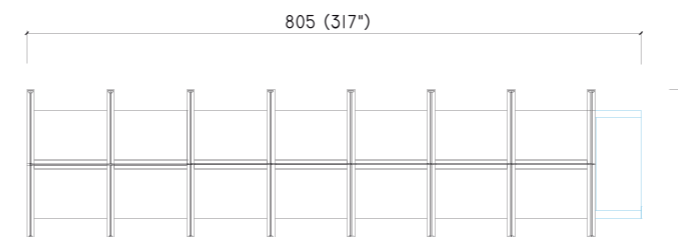

STL 14 For 14 Persons + Moderator

All dimensions in cm (i). Subject to change.

## Optional Accessories

LED lighting system two strips (daylight and colored RGB light strip).  
Lighting control via app.

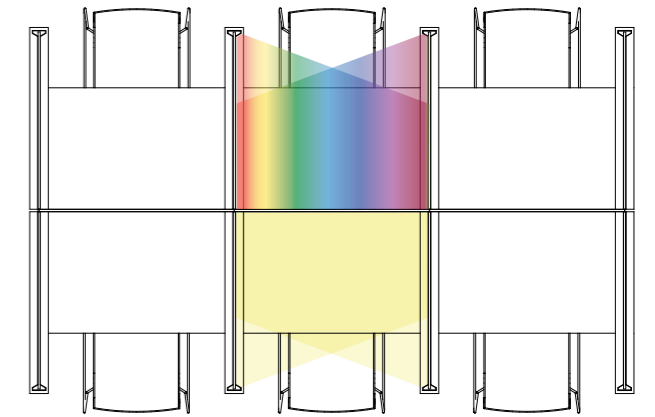

## LED-Module

### Linear LED-RGB light strip

Power connection 24V DC  
Lifetime: 30 000 h  
Radiation Angle: 120°

### Daylight LED light strip

Color-temperature 3 000 K  
Power connection 24V DC  
Lifetime: 30 000 h  
Radiation angle: 120°

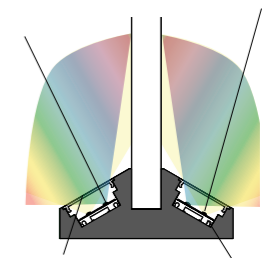

## LED Profile Cover Frosted

## Heat Sink Aluminium Aluminium

## Power Supply

Input: 220-240V ~ / 3.0A (EU)  
100-120V ~ / 6.0A (USA)  
selectable on demand

The SAM Sensory Table system is characterized by ageless aesthetics, enduring and long lasting quality combined with the highest level of convenience. The space aged design promises long-term usability. Its modular design, the multifunctionality, the flexibility of the configuration, the quality of the materials, the mechanical components and the easy assembly ensure outstanding service.

Made in Germany

(Errors and omissions excepted!)



CLT

table system



## CLT-table

The CLT table is designed for data collection by CASA (Computer Aided Sensory Analysis). The work area of the table is made of a robust and highly resistant bicolored 19mm decorative plate. There is more than ample space for evaluation of any type of products and test protocols. Additionally, the system is designed for screen suspension with enough space for keyboard and mouse. Well-thought-out cable management ensures smooth installation of the end devices.

## Technical Data

### Functionality:

The CLT table is designed for data collection by CASA (Computer Aided Sensory Analysis). The work area of the table is made of a robust and highly resistant bicolored 19mm decorative plate. There is more than ample space for evaluation of any type of products and test protocols. Additionally, the system is designed for screen suspension with enough space for keyboard and mouse. Well-thought-out cable management ensures smooth installation of the end devices.

### Material:

Two-tone robust and highly resistant decorative table top, 19 mm (0.75 inch) thick. In the lower area, the stylish grey decor creates a modern work space concealing unsightly cables, especially designed for high traffic of consumers / respondent. The rear partition has a height of 55cm above the table surface and offers enough space to suspend a monitor. To the floor in the rear, a 30cm high recess allows more space and sufficient foot room, creating a comfortable seating position. On the right side, the necessary privacy of the consumer is ensured by a 30cm high partition.

### Equipment:

High back wall for screen mounting.  
Cable entry in table top  
Thin-Client or PC bracket

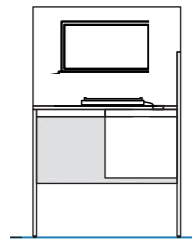

### Optional Accessoires :

Optional vertical cable duct for connections from the ceiling.  
Monitors holder / mounting bracket

## Configuration: CLT-Table

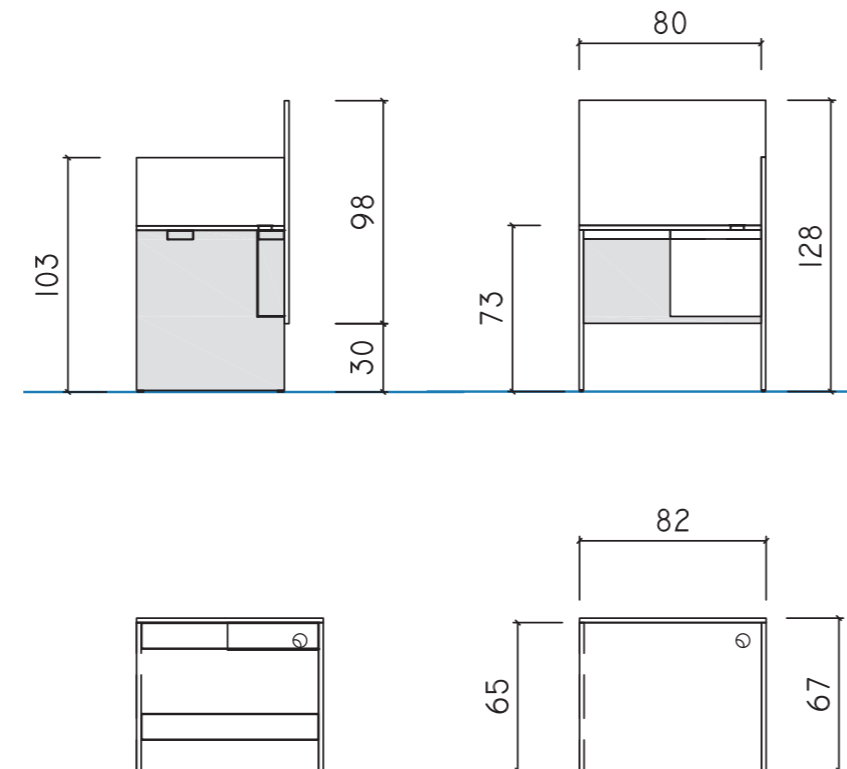

Other configurations or and table sizes possible.

All dimensions in cm (i). Subject to change.



# SCS

sensory cabin system

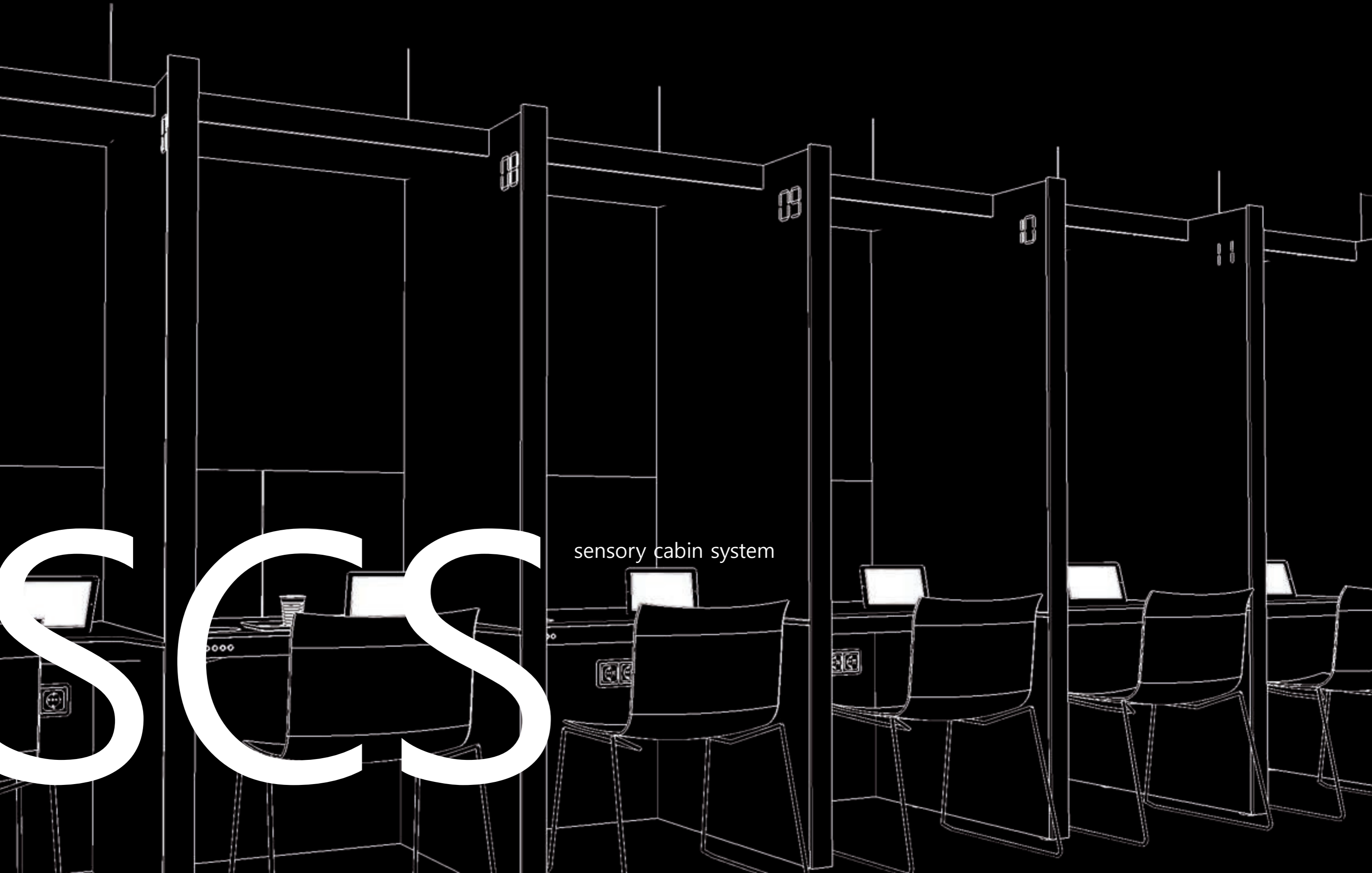



**SCS basic**

**Sensory Booths**

**professional**

The SCS basic sensory booth is the ideal solution for the professional execution of sensory tests. It meets all the requirements required by the sensory test standard DIN EN ISO 8589.

The intelligent lighting system creates ideal and uniform lighting conditions in the test area. The comfortable test station design and its geometry also ensure perfect test conditions in the standardized test procedure.





**SCS pro+**

**Sensory Booths**

**professional**

The SCS pro+ sensory booth is the ideal solution for the professional execution of sensory tests. It meets all the requirements required by the sensory test standard DIN EN ISO 8589.

The intelligent lighting system creates ideal and uniform lighting conditions in the test area. The comfortable test station design and its geometry also ensure perfect test conditions in the standardized test procedure.

With the SCS sensory cabin, the interaction between test and preparation room is optimal.

Due to the many expansion options, an adapted individual customer solution for a professional work area can be implemented.



## High Performance Intelligent, Digitized & Modular

- Outstanding material – robust, unbreakable and timeless
- Easy to assemble
- Intelligent accessories: integrated LED lighting adjustable to the entire color-spectrum, moderator work-space, all types of connections, networking capabilities, data interfaces and much more reflect state of the art technology realized.
- Simple operation by a smartphone, tablet or laptop app.
- Unlimited configurations, adaptable to each room size and shape, allowing adjustability to any requirement for the life your investment.

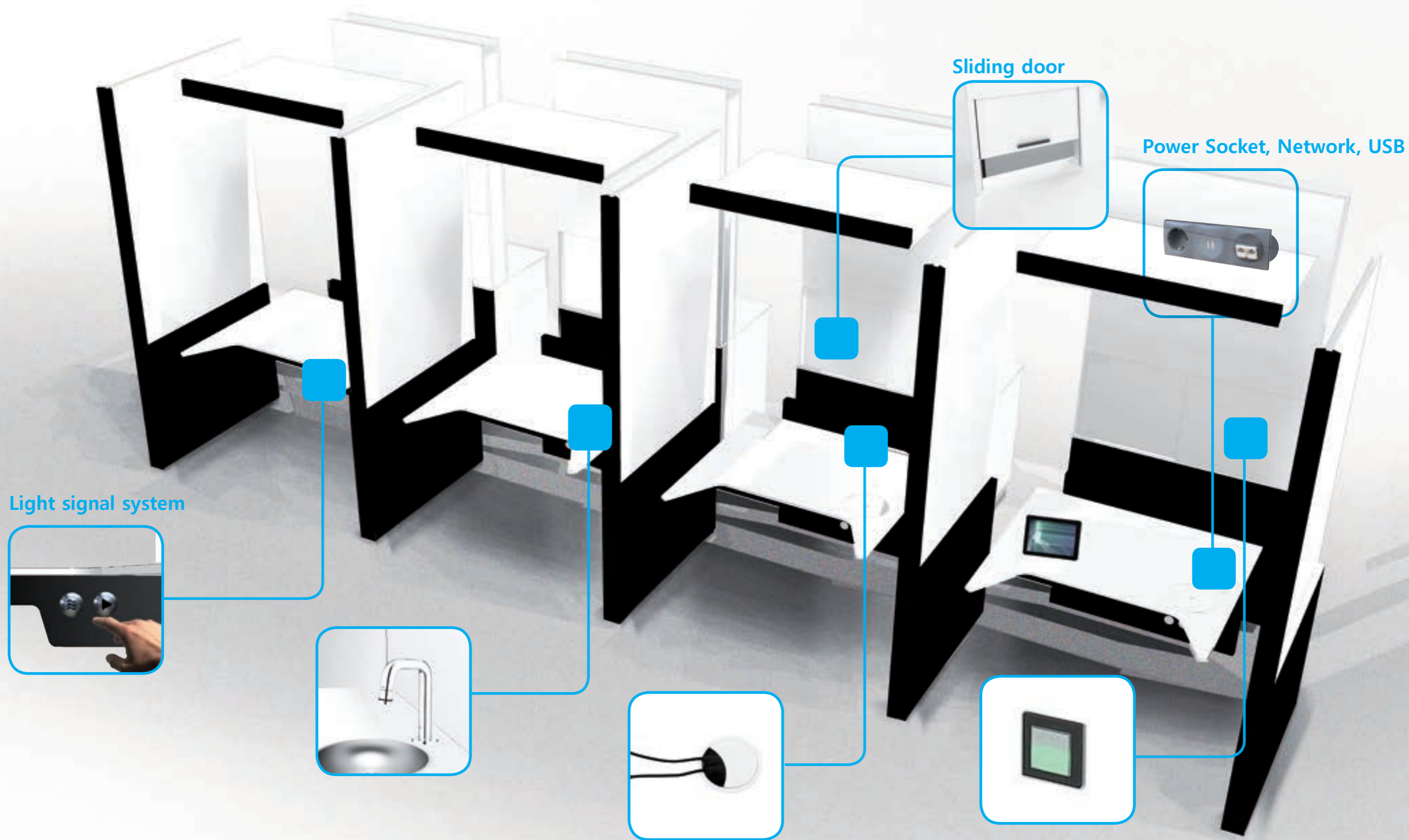

## Unlimited Modular

- Quick and easy assembly
- Regardless of the individual shape of the working space, the sensory cabin system can be easily modified by adding, removing or reconfiguring with working place / Sensory Booth modules.
- A single module makes up one fully wired working place, including power socket, data interface, USB charging port, LAN-connection.

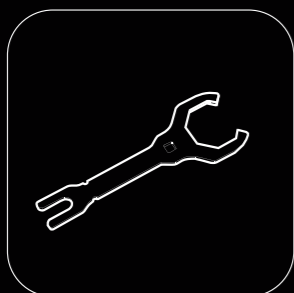



## Enlightening Sensory Booth

- Professional and fully integrated high power LED lighting – crucial for professional product evaluation
- Each working place is homogeneously illuminated, allowing daylight and the entire color spectrum
- Lighting of the working places via remote controlled adjustable
- Room lighting can be included in the light control system



# Technical Data

## Functionality:

The sensory cabin is intended for data collection by CASA (Computer Aided Sensory Analysis).

A light signal system connects the cabin with the preparation room.

The work-table of the SAM sensory cabin is made of CORIAN. The work-table offers enough space for the testing samples.

At the front of the walls, is an LED lighting system, which assures the illumination of the entire working space without any shadows. The LED modul includes two strips (daylight and colored RGB light strip for masking differences in color). Lighting control via app.

The work-table and the walls of the cabin are white.

## Table Plate / Working Space:

Solid Surface, 12 mm (0,5") strength. Choice of colors. Integrated brush-sealing protecting cable routing from dirt and dust.

## Accessories:

Panel flap with integrated sockets: power socket, LAN-connection, 1 USB port. Conduit for easy cable routing.

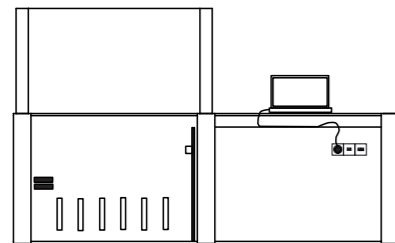

## Operation:

- via remote controlled
- optional control panel via app for laptop, tablet or smartphone operating all functions and connecting with room lighting, blinds, air-condition, door-communication, etc.

# Configuration: SCS basic

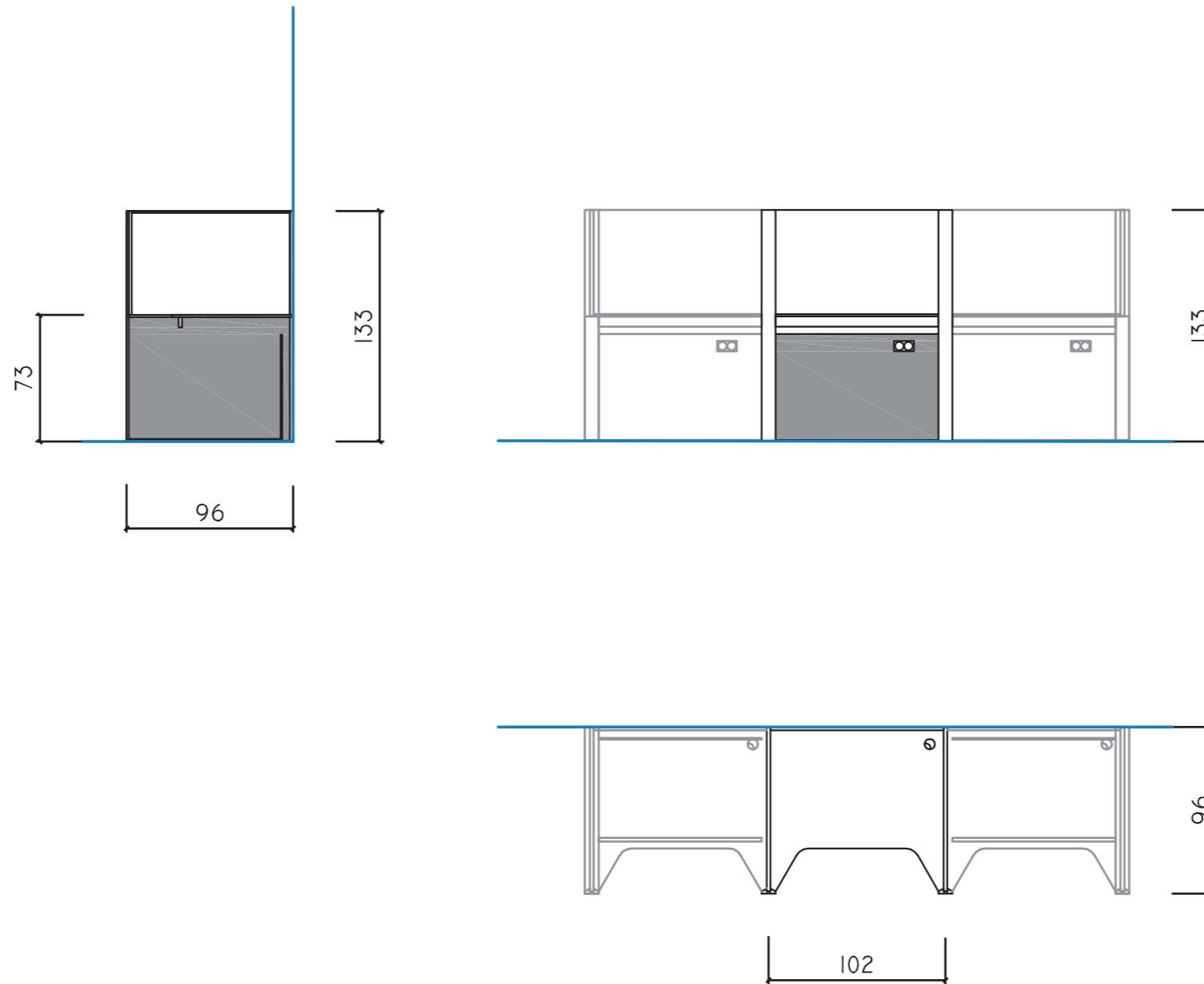

Other configurations or and table sizes possible.

All dimensions in cm (i). Subject to change.

## Optional Accessories

LED lighting system two strips (daylight and colored RGB light strip).  
Lighting control via app.

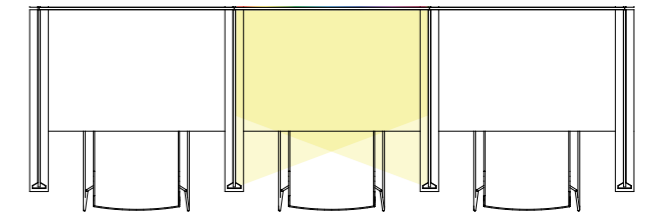
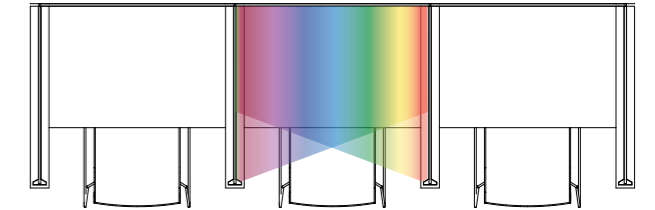

## LED-Module

### Linear LED-RGB light strip

Power connection 24V DC

Lifetime: 30 000 h

Radiation Angle: 120°

### Daylight LED light strip

Color-temperature 3 000 K

Power connection 24V DC

Lifetime: 30 000 h

Radiation angle: 120°

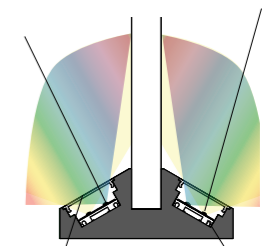

LED Profile Cover Frosted

Heat Sink Aluminium  
Aluminium

## Power Supply

Input: 220-240V ~ / 3.0A (EU)

100-120V ~ / 6.0A (USA)

selectable on demand

The SAM Sensory Cabin system is characterized by ageless aesthetics, enduring and long lasting quality combined with the highest level of convenience. The space aged design promises long-term usability. Its modular design, the quality of the materials, the mechanical components and the easy assembly ensure outstanding service.

Made in Germany

(Errors and omissions excepted!)

# Technical Data

## Functionality:

The sensory cabin is intended for data collection by CASA (Computer Aided Sensory Analysis).

A light signal system connects the cabin with the preparation room.

The work-table of the SAM sensory cabin is made of CORIAN. The work-table offers enough space for the testing samples.

At the front of the walls, is an LED lighting system, which assures the illumination of the entire working space without any shadows. The LED modul includes two strips (daylight and colored RGB light strip for masking differences in color). Lighting control via app.

The work-table and the walls of the cabin are white.

## Table Plate / Working Space:

Solid Surface, 12 mm (0,5") strength. Choice of colors. Integrated brush-sealing protecting cable routing from dirt and dust.

## Accessories:

Panel flap with integrated sockets: power socket, LAN-connection, 1 USB port. Conduit for easy cable routing.

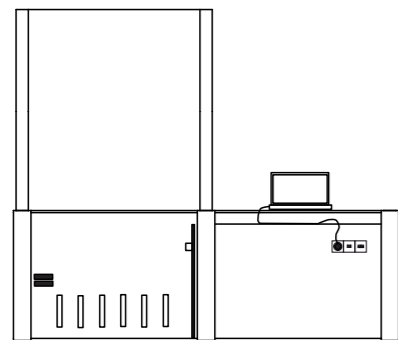

## Operation:

- via remote controlled
- optional control panel via app for laptop, tablet or smartphone operating all functions and connecting with room lighting, blinds, air-condition, door-communication, etc.

# Configuration: SCS pro+

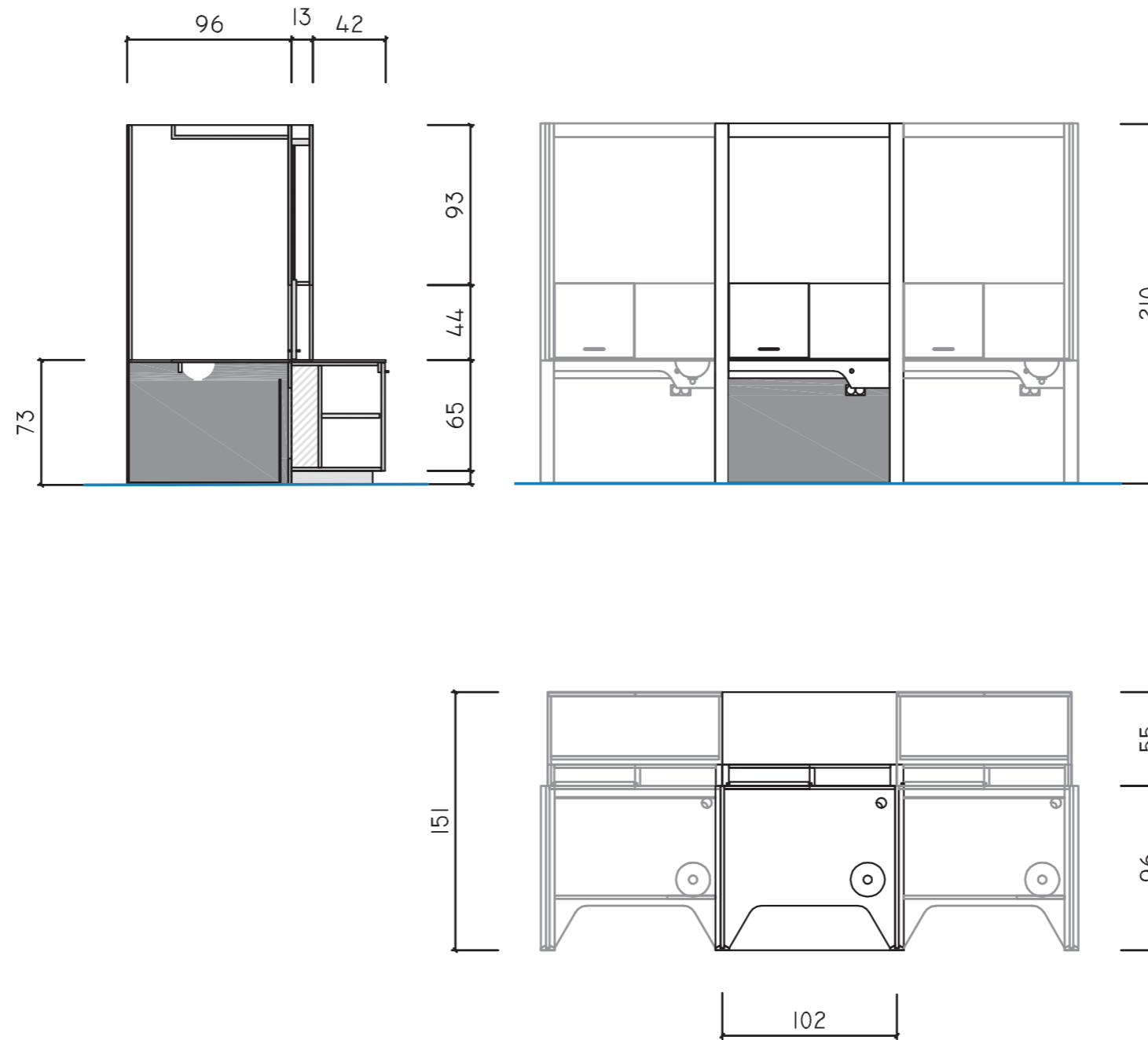

Other configurations or and table sizes possible.

All dimensions in cm (i). Subject to change.

## Optional Accessories

LED lighting system two strips (daylight and colored RGB light strip).  
Lighting control via app.

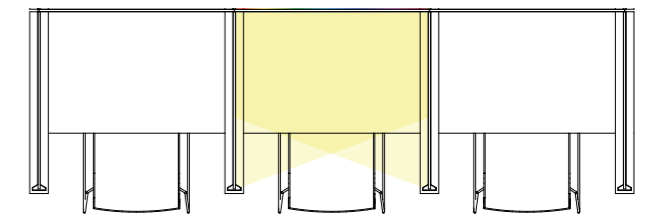
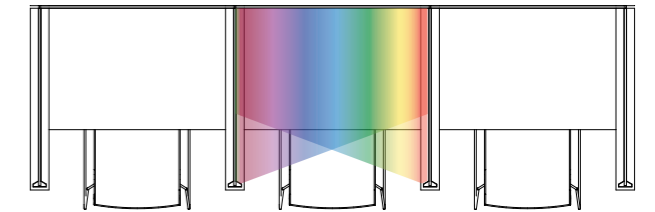

## LED-Module

### Linear LED-RGB light strip

Power connection 24V DC

Lifetime: 30 000 h

Radiation Angle: 120°

## Daylight LED light strip

Color-temperature 3 000 K

Power connection 24V DC

Lifetime: 30 000 h

Radiation angle: 120°

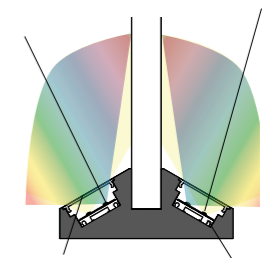

LED Profile Cover Frosted

Heat Sink Aluminium  
Aluminium

## Power Supply

Input: 220-240V ~ / 3.0A (EU)

100-120V ~ / 6.0A (USA)

selectable on demand

The SAM Sensory Cabin system is characterized by ageless aesthetics, enduring and long lasting quality combined with the highest level of convenience. The space aged design promises long-term usability. Its modular design, the quality of the materials, the mechanical components and the easy assembly ensure outstanding service.

Made in Germany

(Errors and omissions excepted!)



# Material – Practical, Unbreakable and Timeless

Solid surface material is a composite material composed of an acrylic mass, hardened natural minerals (about 75%) and pigments.

With its functional properties, solid surface material can meet the maximum requirements placed on a first-class material in Lab furnitures, preparation kitchens and bathrooms as well as in all conference and training rooms. Therefore it also can be used in high-traffic areas.

Color: Pure White

SWISSCDF (Compact Density Fibreboard) is a black stained HDF board with a high density (>1000 kg/m<sup>3</sup>). Thanks to its construction and finishing with a multi-layer coating of melamine films, SWISSCDF sets new dimensions in design and construction in the area of residential and public interiors. This natural, wood-based board stands out for its stability, scratch resistance, splash water resistance and low flammability.

## Solid Surface

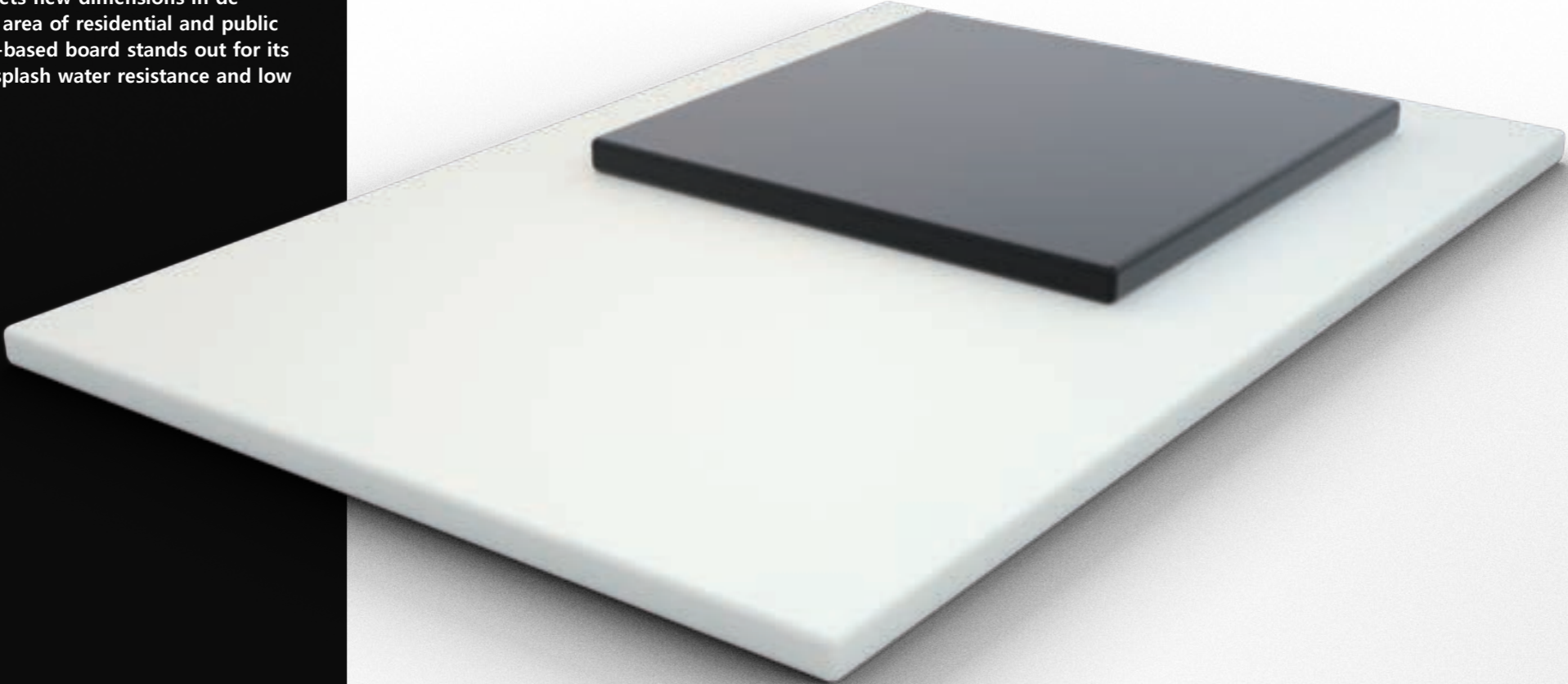

Antistatic



Hydro Repellent



Hygienic



Resistance to Impact



Mold Resistant



Environmentally Friendly



Easy to Clean



Suitable for Contact with Food

\* Colors may differ slightly



sensory cabin system light

SCS

light



## SCS light

## Sensory Booths

### light

The sensory booth SCS light is the ideal solution for the professional implementation of sensory tests. It meets all the requirements of the sensory test standard DIN EN ISO 8589.

The intelligent lighting system ensures the right lighting conditions in the test area. The functional design of the test stand and its geometry also ensure perfect test conditions in the standardized test process.

With the SCS sensory cabin, the interaction between the test and preparation room is optimal.

Due to the many expansion options, an adapted individual customer solution for a professional workspace can be implemented.

Layout:

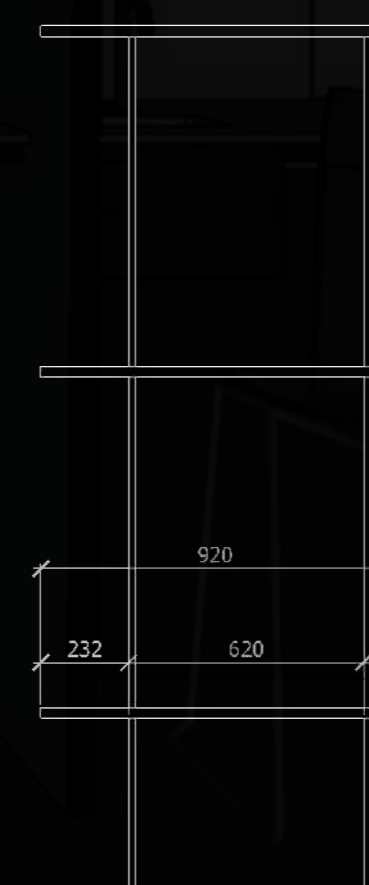



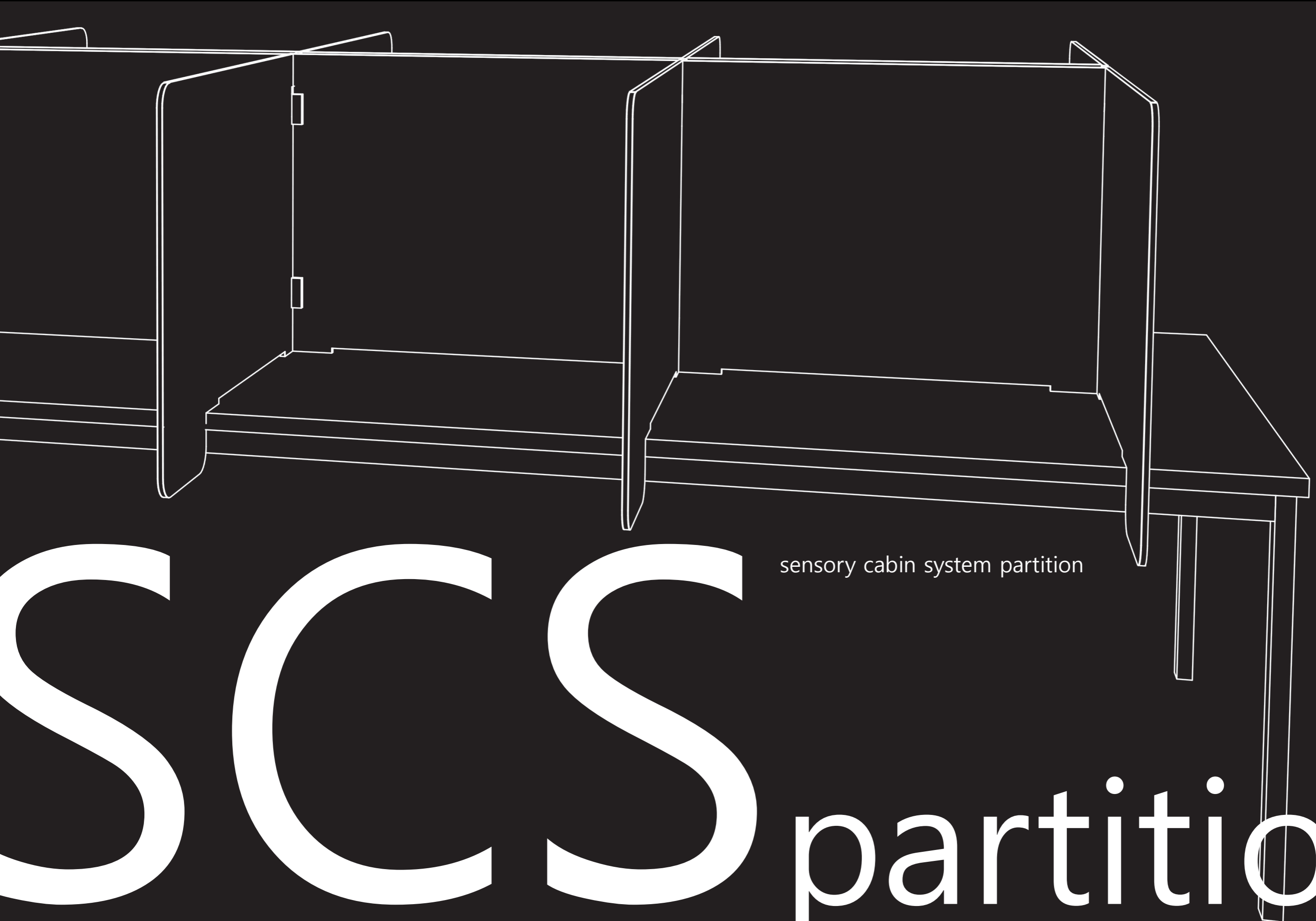

sensory cabin system partition

# SCS partition

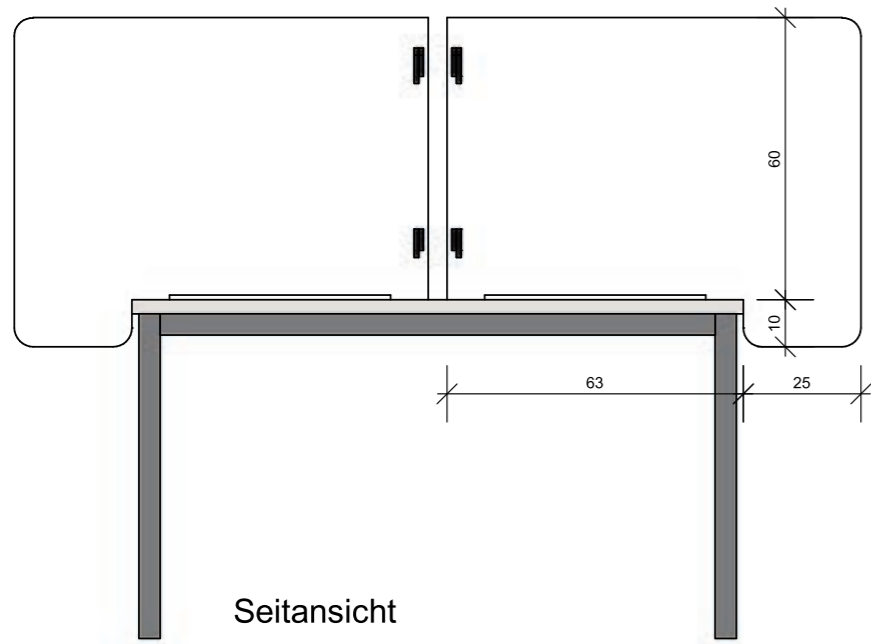

# SCS partition panel

## Sensory Booths

### table partition panel

The partition wall system consists of SWISS CDF

A stable, scratch and splash water resistant wood-based panel

Plug-in connections make assembly tool-free

Rubber feet protect the table and prevent it from slipping

Individually configurable

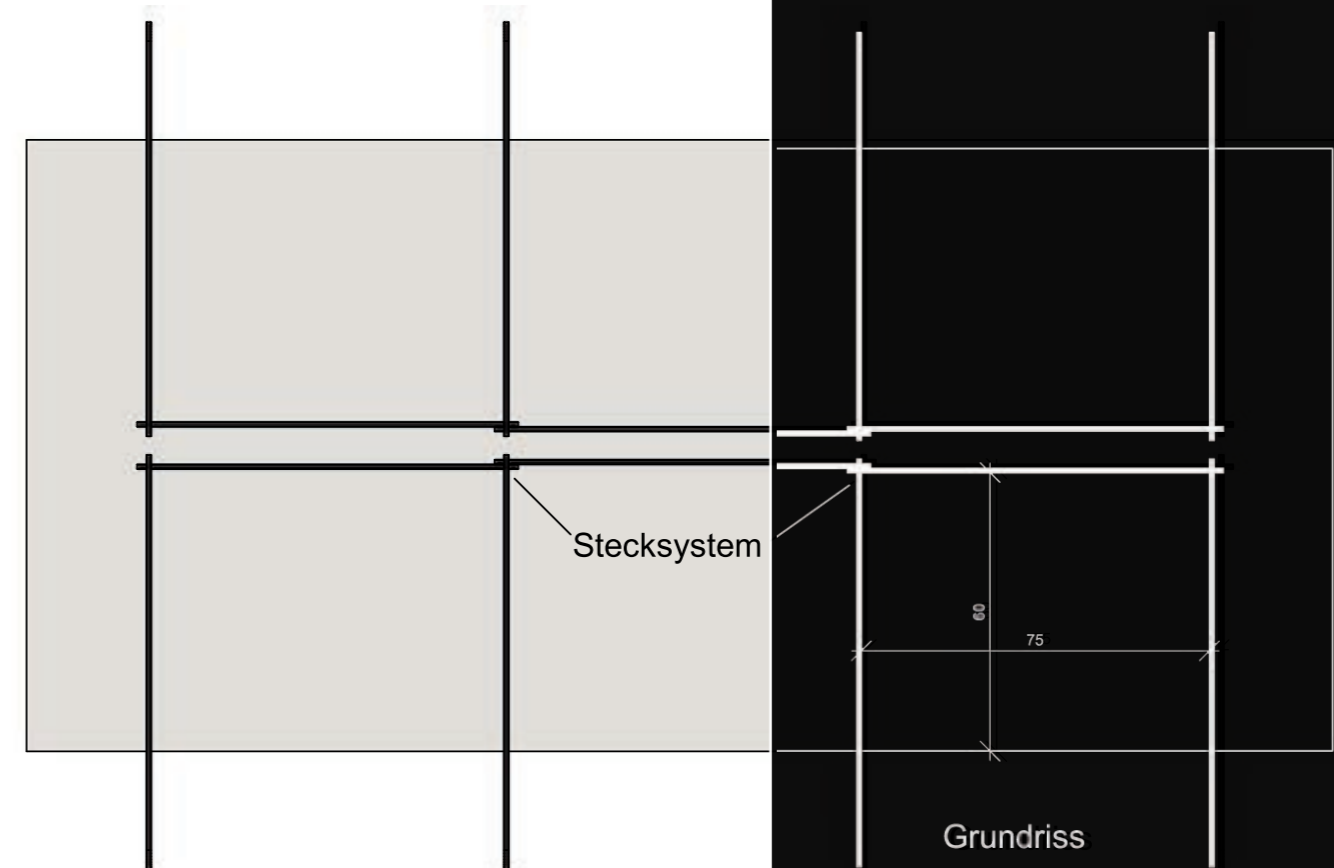
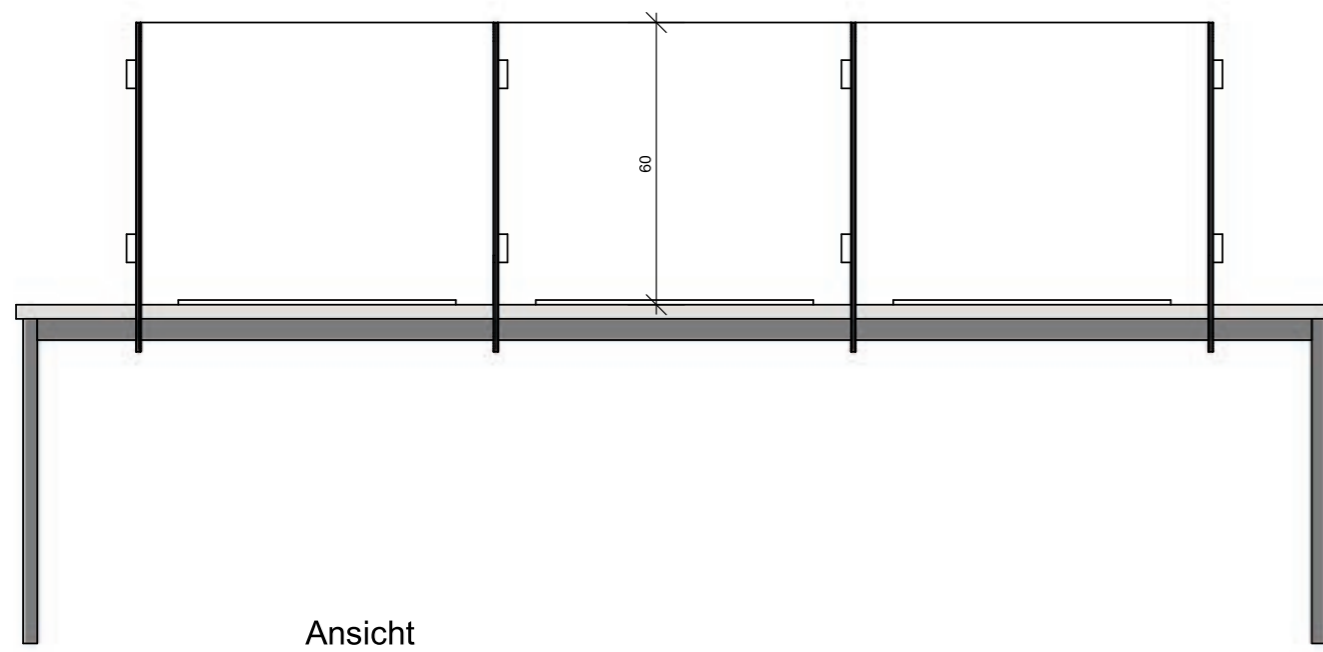



## Points of Difference What sets it apart

- Jointless, hygienic and laboratory-suitable Corian worktops in the test and preparation area
- Space saving and with maximum test standard
- Modular and expandable at any time
- Intelligent LED lighting solution RGB color-controlled
- Sliding door vertical for ideal loading
- Fully accessible installation level for water, electricity and data cables
- Integrated cable management for input devices
- Junction boxes for power, network or USB freely selectable
- Practical materialization
- Design-oriented modern design language
- Clear understandable manual push button control for status signal
- Optional with fixed water connection for spittoon with ring purge or assembly fitting
- Integrated height adjustment for precise alignment
- Prepared for installation of ventilation elements and emergency lighting





SAM Sensory and Marketing International GmbH  
Oetztaler Strasse 1  
D-81373 Munich – Germany  
+ 49 89 743 767 0

[sam-d@samresearch.com](mailto:sam-d@samresearch.com)  
[www.samresearch.com](http://www.samresearch.com)

**Global Network | 120 Partners | 50 Countries**